

ASSEMBLING INSTRUCTION

LEGEND

LICENSE PLATE

DH9104-2-20

WWW.BARRACUDAMOTO.COM

- | | | |
|---|--|--|
| <p>1. BRACKET
STAFFA
SOPORTE
HALTERUNG
SUPPORT</p> <p>2. ALLEN SCREW M8X16
VITE A BRUGOLA M8X16
TORNILLO ALLEN M8X16
INBUSSCHRAUBE M8X16
VIS ALLEN M8X16</p> <p>3. SELF-BLOCKING NUT
DADO AUTOBLOCCANTE
AUTO TUERCA DE BLOQUEO
SELBSTVERRIEGLUNG MUTTER
ECROU AUTO-BLOQUANT</p> | <p>4. ALLEN SCREW M8X30
VITE A BRUGOLA M8X30
TORNILLO ALLEN M8X30
INBUSSCHRAUBE M8X30
VIS ALLEN M8X30</p> <p>4. EXHAUST BRACKET
STAFFA SCARICO
SOPORTE DE ESCAPE
AUSPUFF HALTERUNG
SUPPORT D'ÉCHAPPEMENT</p> <p>6. SOCKET HEAD CAP SCREW M4X10
VITE A TESTA CILINDRICA M4X10
TORNILLO ALLEN CABEZA CILINDRICA M4X10
INNENSECHSKANTSCHRAUBE M4X10
BOUCHON À VIS ALLEN M4X10</p> | <p>7. WASHER Ø 4
RONDELLA Ø 4
ARANDELA Ø 4
SCHEIBE Ø 4
RONDELLE Ø 4</p> <p>8. NUT Ø 4
DADO Ø 4
TUERCA Ø 4
MUTTER Ø 4
ECROU Ø 4</p> |
|---|--|--|

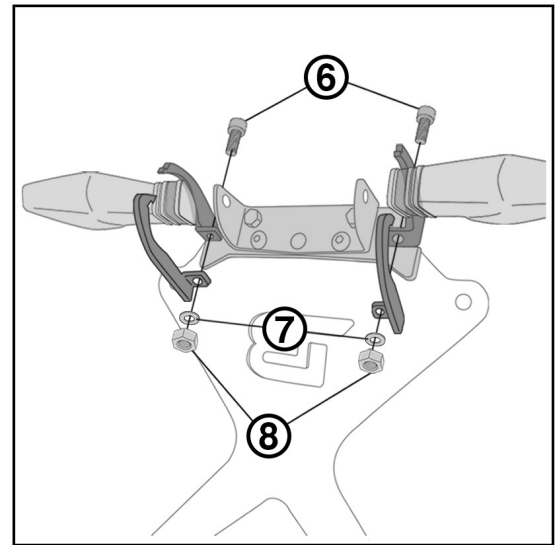
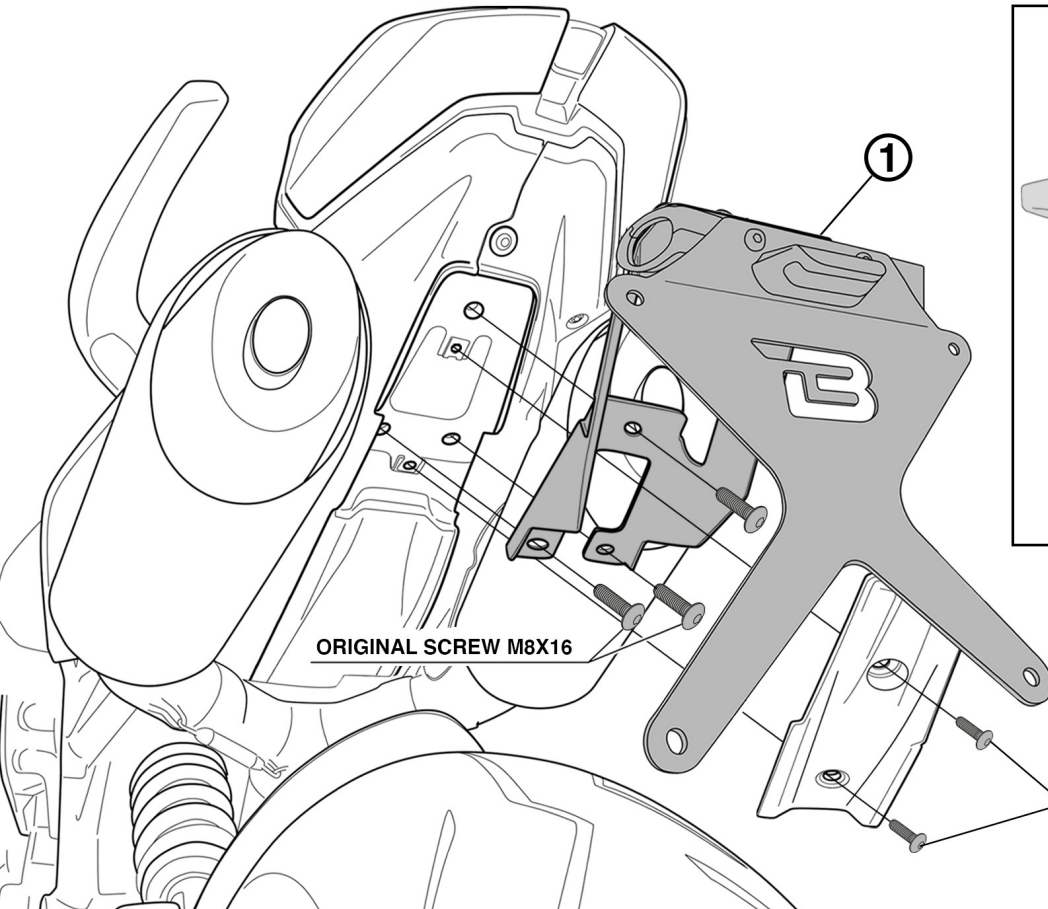
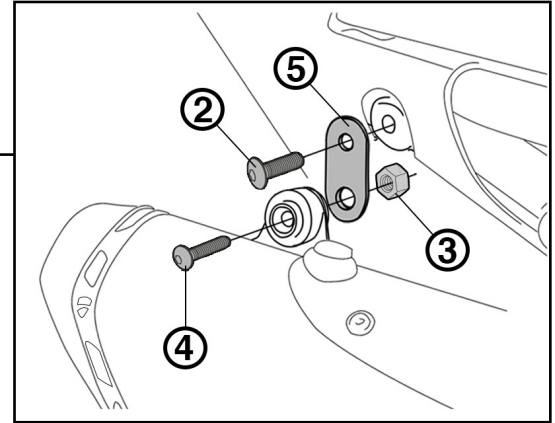
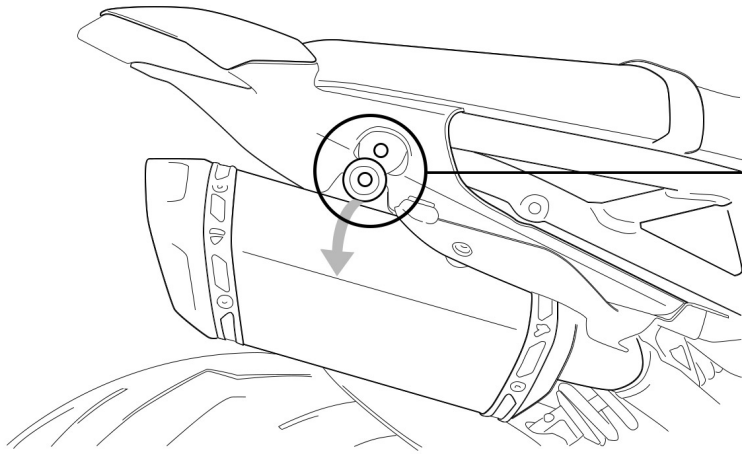

EN: DO NOT MOUNT ADDITIONAL PARTS OR PLATES TO THE X PLATE TO AVOID EXTRA WEIGHT AND POSSIBLE BREAKINGS.

IT: NON MONTARE PIASTRE E/O ULTERIORI ELEMENTI ALLA X TARGA PER EVITARE APPESANTIMENTI E POSSIBILI ROTTURE.

ES: NO MONTE PIEZAS O PLACAS ADICIONALES EN LA PLACA X PARA EVITAR PESO ADICIONAL Y POSIBLES ROTURAS.

DE: MONTIEREN SIE KEINE ZUSÄTZLICHEN TEILE ODER PLATTEN AN DER X-PLATTE, UM ZUSÄTZLICHES GEWICHT UND MÖGLICHE BRÜCHE ZU VERMEIDEN.

FR: NE MONTEZ PAS DE PIÈCES OU DE PLAQUES SUPPLÉMENTAIRES SUR LA PLAQUE X POUR ÉVITER UN POIDS SUPPLÉMENTAIRE ET D'ÉVENTUELLES CASSURES.

EN: WE RECOMMEND AN INCLINATION NOT MORE THAN 30° TO AVOID PENALTIES AND POSSIBLE STRUCTURAL DAMAGES.

IT: CONSIGLIAMO UN'INCLINAZIONE NON SUPERIORE AI 30° PER EVITARE SANZIONI E POSSIBILI DANNI STRUTTURALI.

ES: RECOMENDAMOS UNA INCLINACIÓN DE NO MÁS DE 30° PARA EVITAR SANCIONES Y POSIBLES DAÑOS ESTRUCTURALES.

DE: WIR EMPFEHLEN EINE STEIGUNG VON NICHT MEHR ALS 30°, UM STRAFEN UND MÖGLICHE STRUKTURELLE SCHÄDEN ZU VERMEIDEN.

FR: NOUS VOUS RECOMMANDONS DE NE PAS INCLINER À PLUS DE 30° POUR ÉVITER LES PÉNALITÉS ET LES DOMMAGES STRUCTUREL POSSIBLES.